

Introduction to UML 2.0

(slides from '06 CS550 by Prof.Bae)



UML Introduction

What is UML?

- **Unified Modeling Language**
 - Visual language for specifying, constructing and documenting
- Maintained by the OMG (Object Management Group)
 - Website: <http://www.omg.org>
- Object-oriented
- Model / view paradigm
- Target language independent



Model / View Paradigm

- Each diagram is just a view of part of the system
- Together, all diagrams provides a complete picture

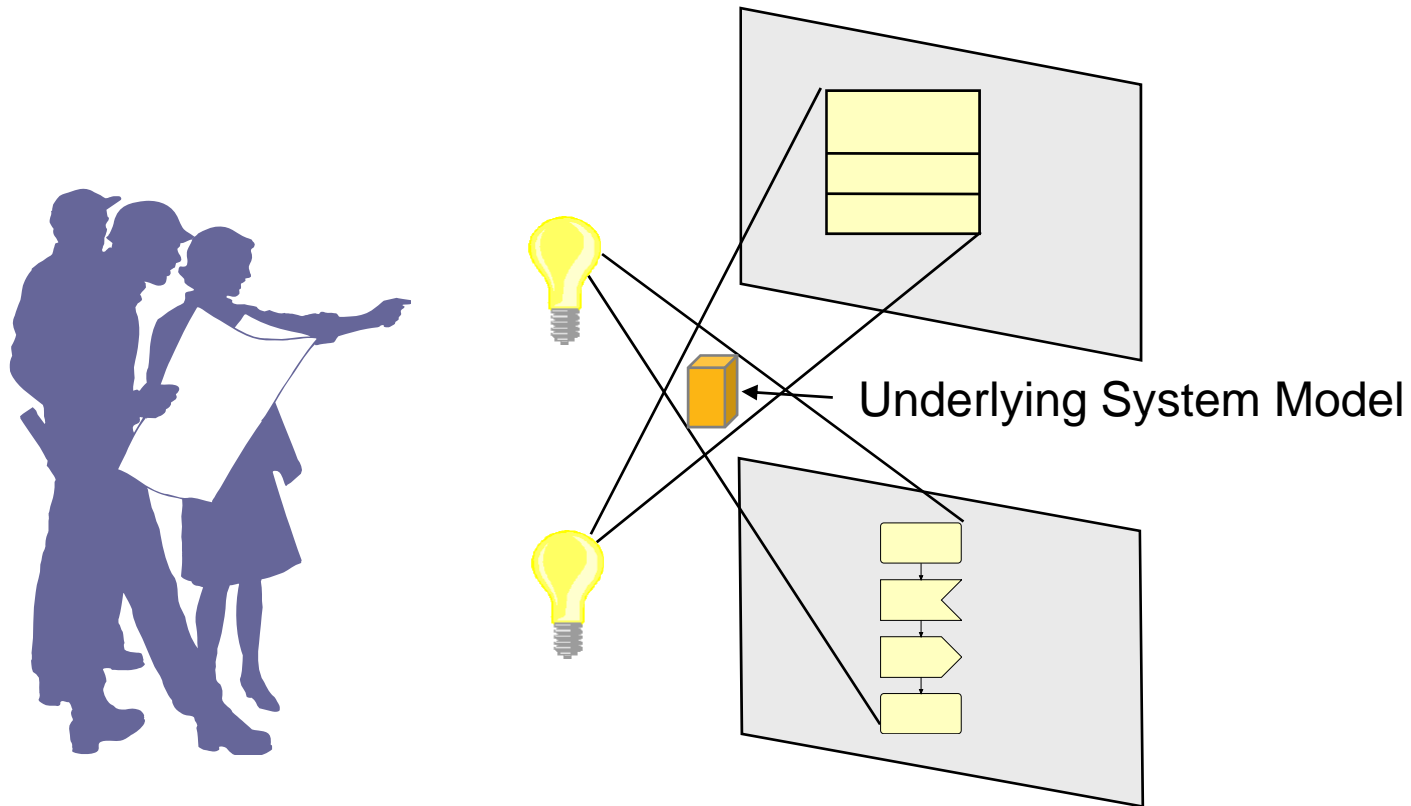

Classification of UML diagram types

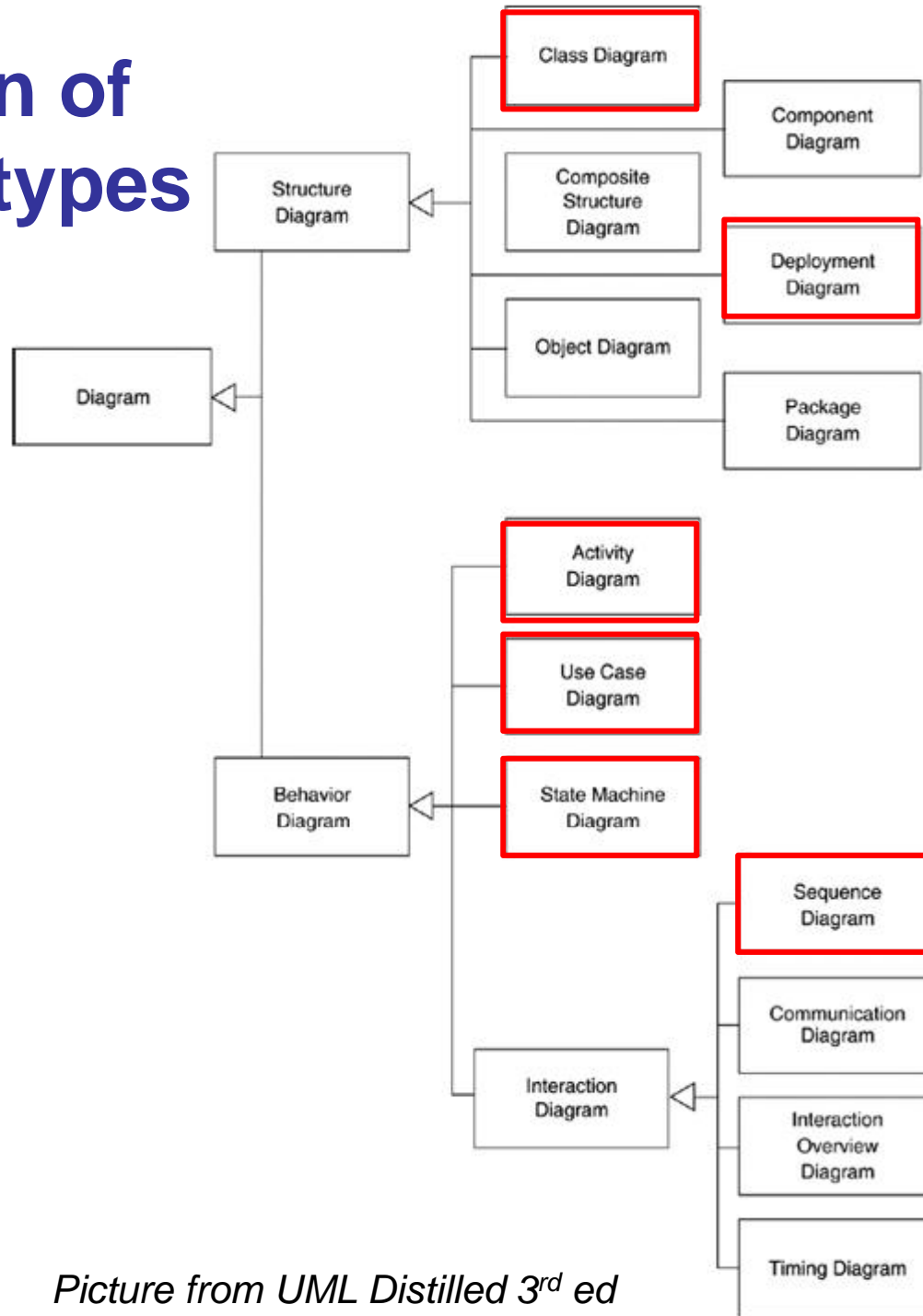

Picture from UML Distilled 3rd ed

Usage of UML

- UML as sketch
 - Selectivity (abstraction) is the key
 - No formal semantics are given
- UML as blueprint
 - Completeness is the key
- UML as a programming language
 - To generate C/Java code from UML diagrams
 - No formal definition exists of how the UML maps to any particular programming language



Use Case Diagrams



What is a Use Case?

Use Case ~ A **behavior** or coherent set of behaviors triggered by events **sent to the system** by human user(s), other systems, hardware components, or an internal clock

Use Case Diagrams

- Describe WHAT the system will do at a high-level

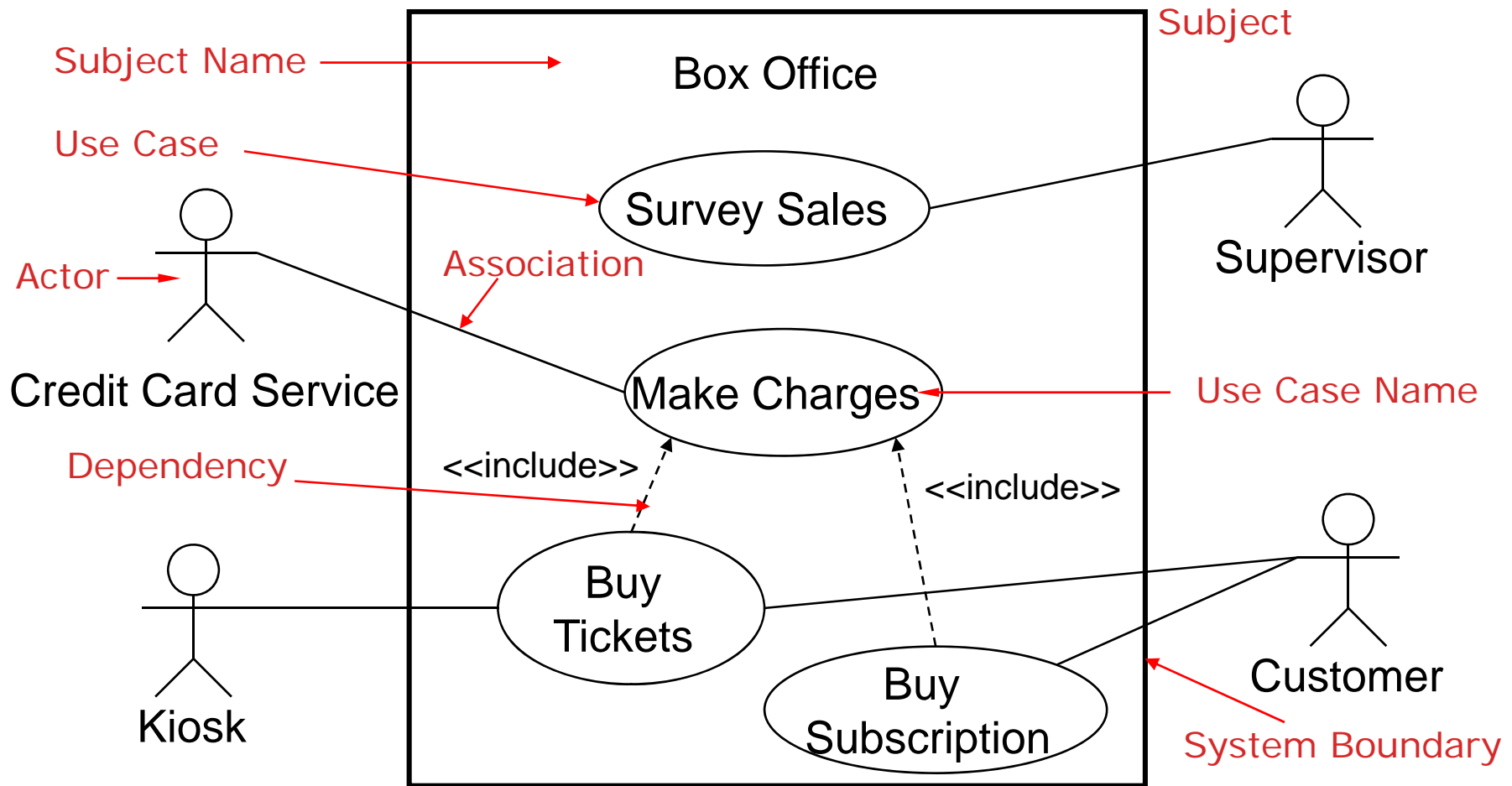

Actor

- Someone or some thing that must interact with the system
 - Users, external systems, devices

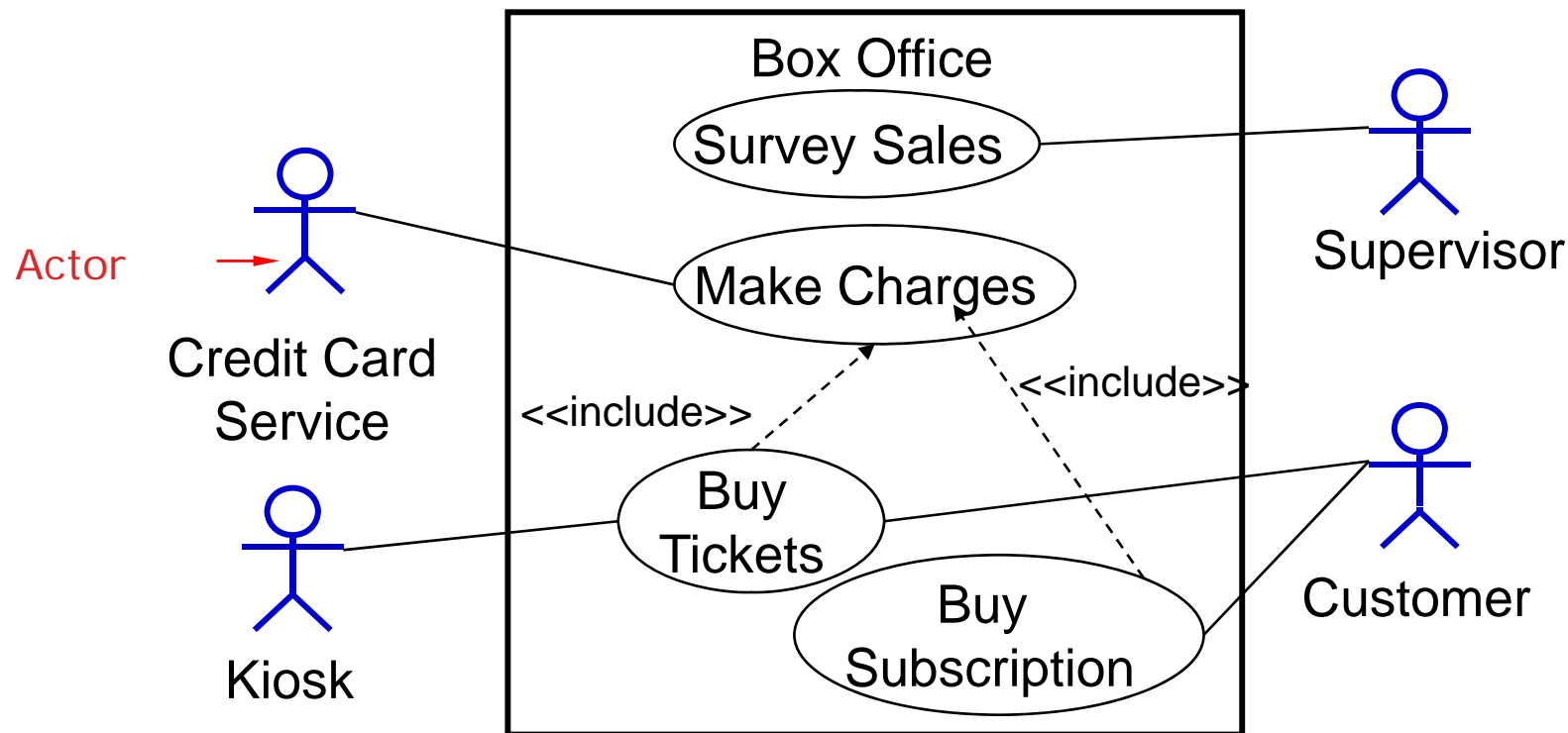

An Actor is a Role

- An actor defines a single role played by users in their interactions with the system:
 - Multiple users can play a single role
 - A single user may play multiple roles

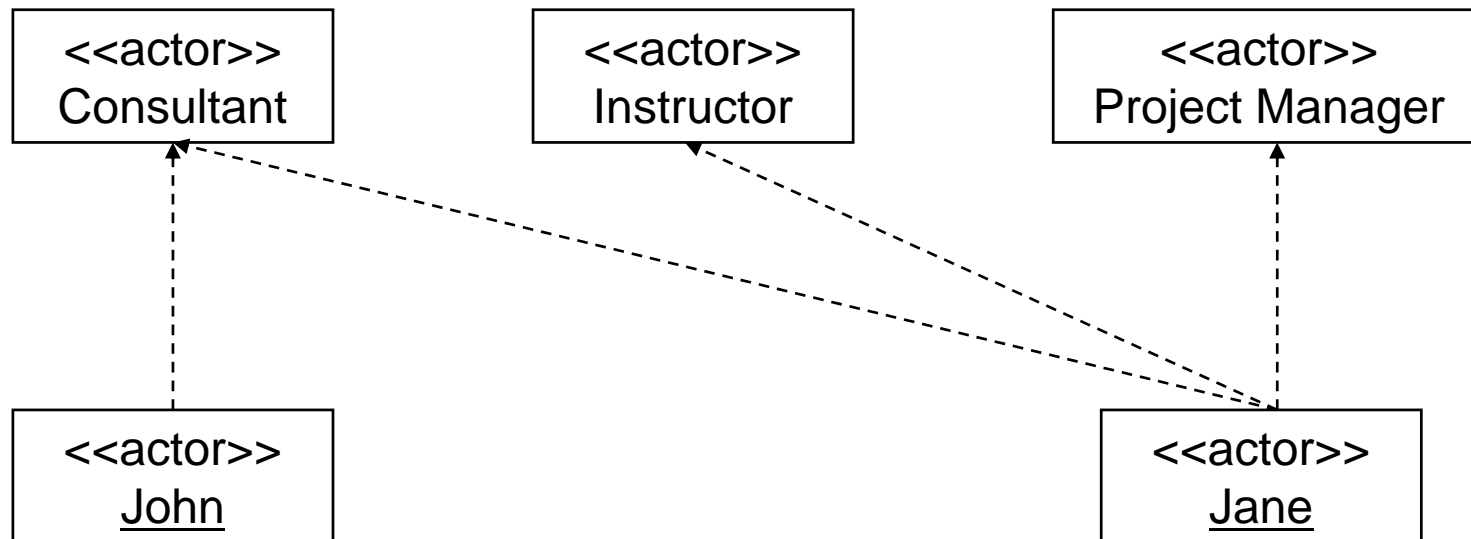

Identifying Actors

- Useful questions
 - Who will **use the main functionality** of the system (primary actors)?
 - Who will need support from the system to their daily tasks?
 - Who will need to maintain, administrate, and keep the system working (secondary actors)?
 - Which hardware devices does the system need to handle?
 - With which other systems does the system need to interact?
 - Who or what has an interest in the results (the value) that the system produces?

(From :oopsia.snu.ac.kr/research/UML/)

Use Case

- Unit of functionality expressed as a transaction among actors and the subject
- Interaction between one or more actors and the system

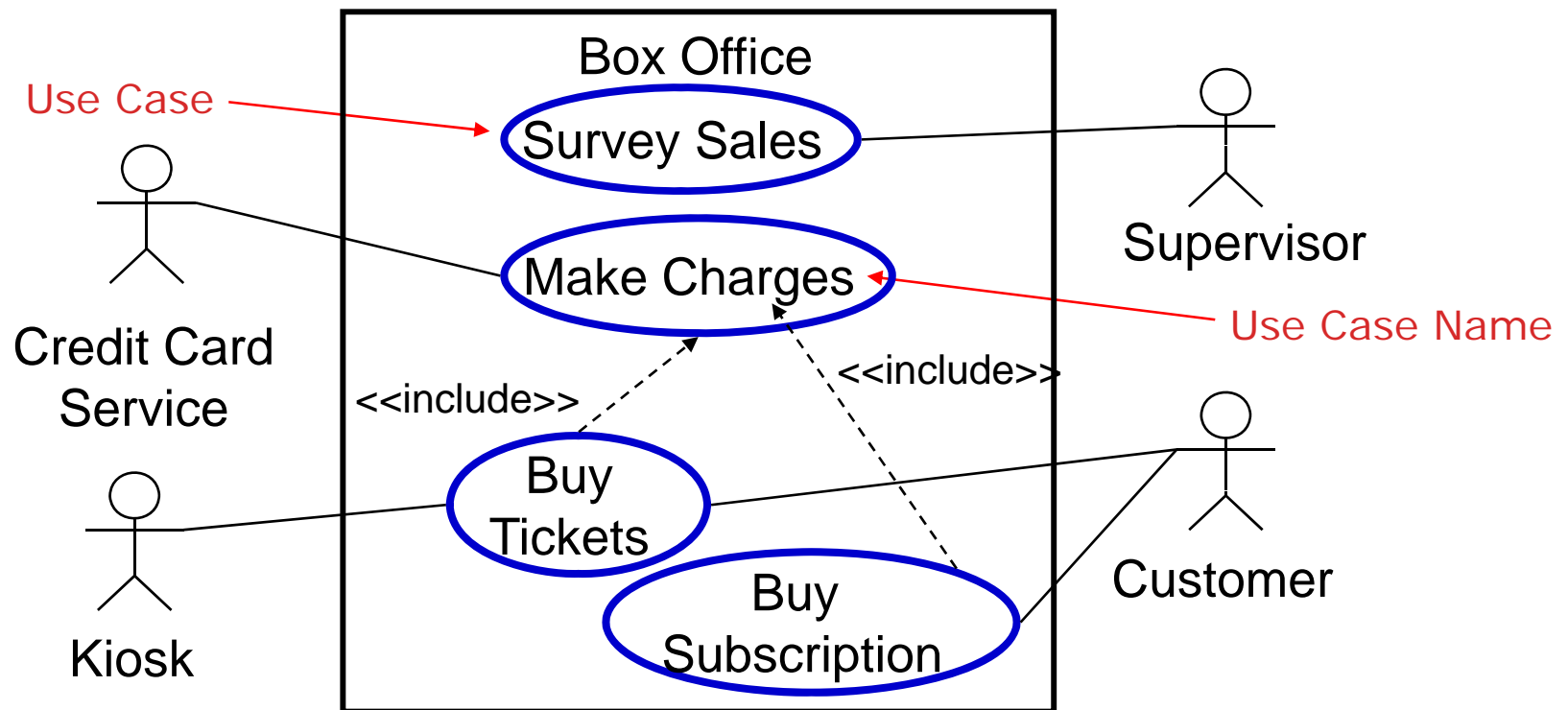

Use Case

- Identifying Use Cases
 - Which **functions** does the **actor require** from system?
 - Does the actor need to **read, create, destroy, modify, or store** some kind of **information** in the system?
 - Does the actor have **to be notified about events** in the system
 - Could the actor's daily work be simplified or made more **efficient through new functions** in the system

An Example of Use Case Text

- Buy a Product
 - **Main Success Scenario :**
 - 1 . **Customer browses catalog and selects items to buy**
 - 2 . **Customer goes to check out**
 - 3 . **Customer fills in shipping information (address ; next-day or 3-day delivery)**
 - 4 . **System presents full pricing information, including shipping**
 - 5 . **Customer fills in credit card information**
 - 6 . **System authorizes purchase**
 - 7 . **System confirms sale immediately**
 - 8 . **System sends confirming e-mail to customer**
 - **Extensions :**
 - 3a : Customer is regular customer**
 - .1 : System displays current shipping, pricing, and billing information
 - .2 : Customer may accept or override these defaults, returns to MSS at step 6
 - 6a : System fails to authorize credit purchase**
 - .1 : Customer may reenter credit card information or may cancel

Subject Symbol

- Indicate system boundary
 - Classifier that realizes behavior defined by a use case

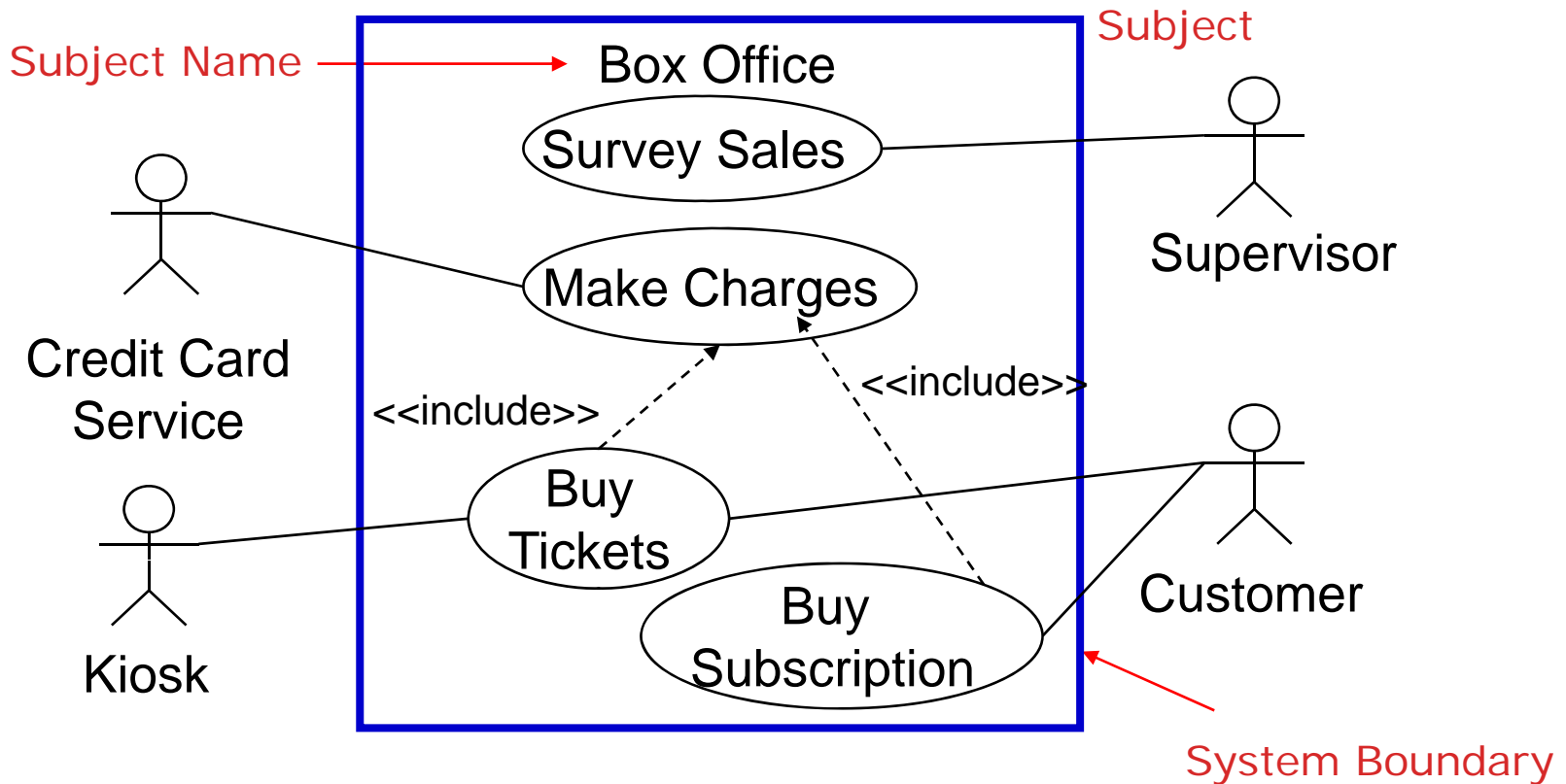

Association

- Represent bi-directional communication between the actor and the system
- Drawn between an actor and a use case

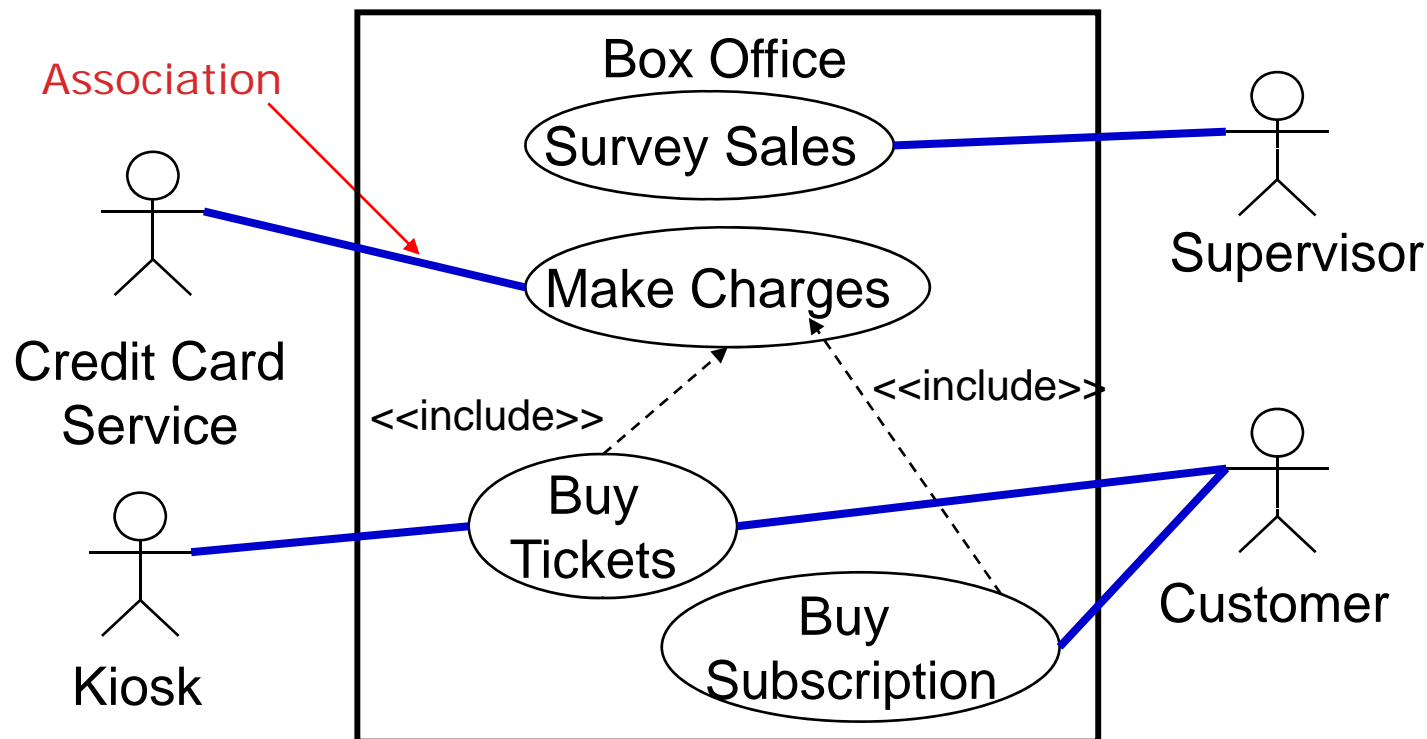

Dependency – Include

- Represent relationship from a *base* to an *inclusion* use case
- Imply a Use Case **calls another Use Case**
- Primarily used to **reuse** behavior common to several Use Cases

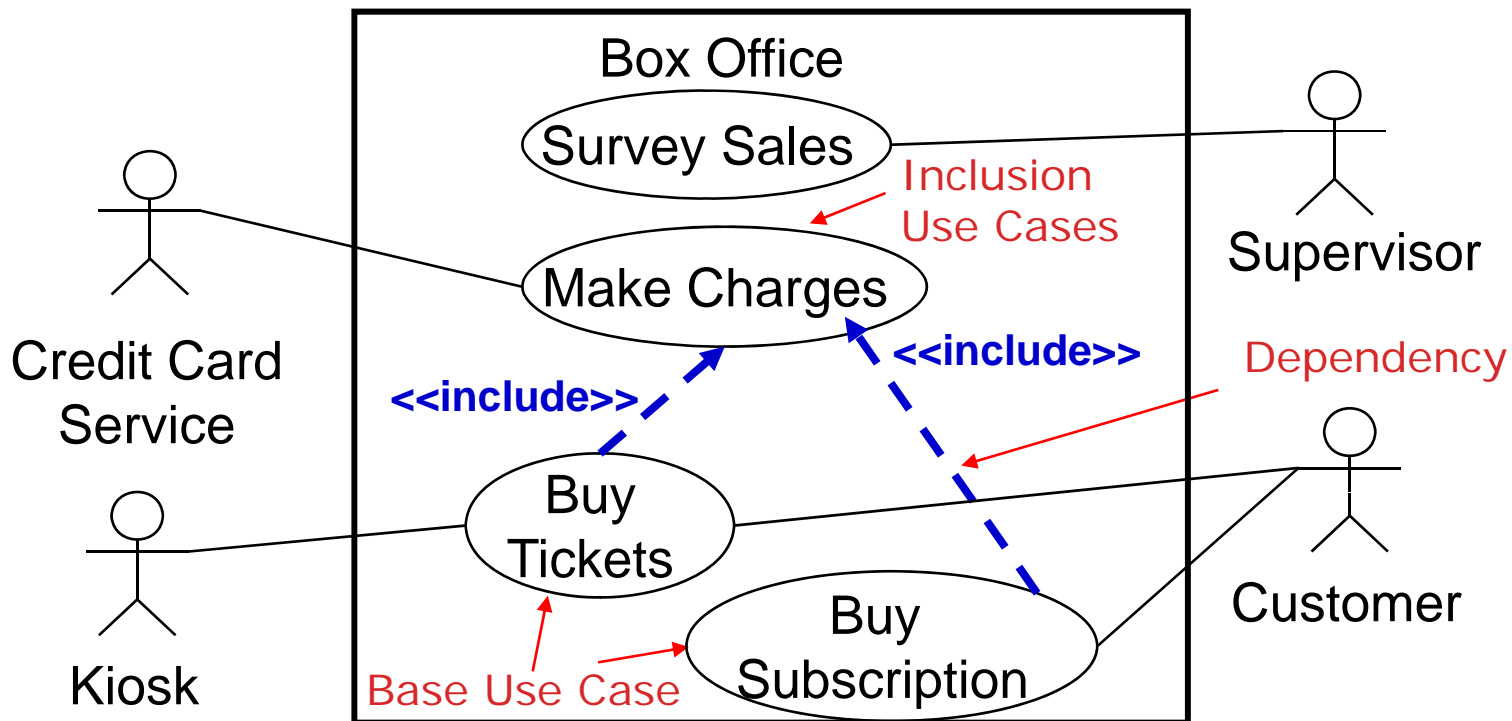

Dependency – Extend

- Used when some **additional** behavior should be added
 - Models **optional or conditional** behavior
 - Show infrequent events

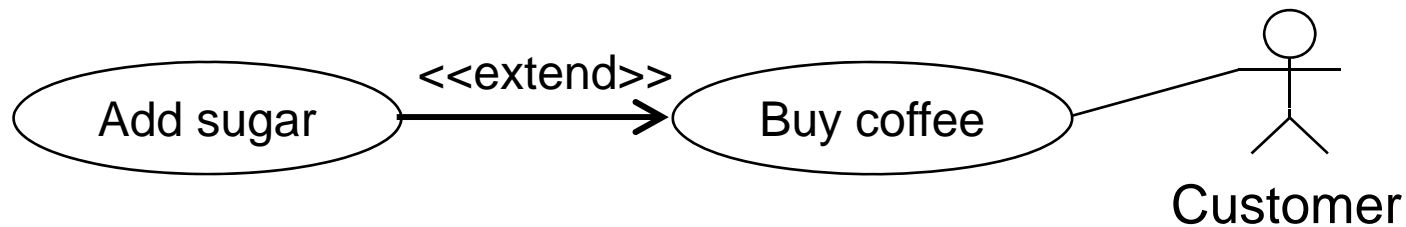

Tips for Use Case Modeling

- Make sure that each use case describes a significant chunk of system usage that is **understandable by both domain experts and programmers**
- When defining use cases in text, use **nouns and verbs accurately and consistently** to help derive objects and messages for interaction diagrams
- **Factor out common usages** that are required by multiple use cases
 - If the usage is required use `<<include>>`
 - If the base use case is complete and the usage may be optional, consider use `<<extend>>`
- A use case diagram should
 - contain only use cases at the **same level of abstraction**
 - include **only actors** required
- Large numbers of use cases should be organized into packages

(From [:oopsia.snu.ac.kr/research/UML/](http://oopsia.snu.ac.kr/research/UML/))



Class Diagrams

Class Diagrams

- Description of **static** structure
 - Showing the **types** of objects in a system and the **relationships** between them

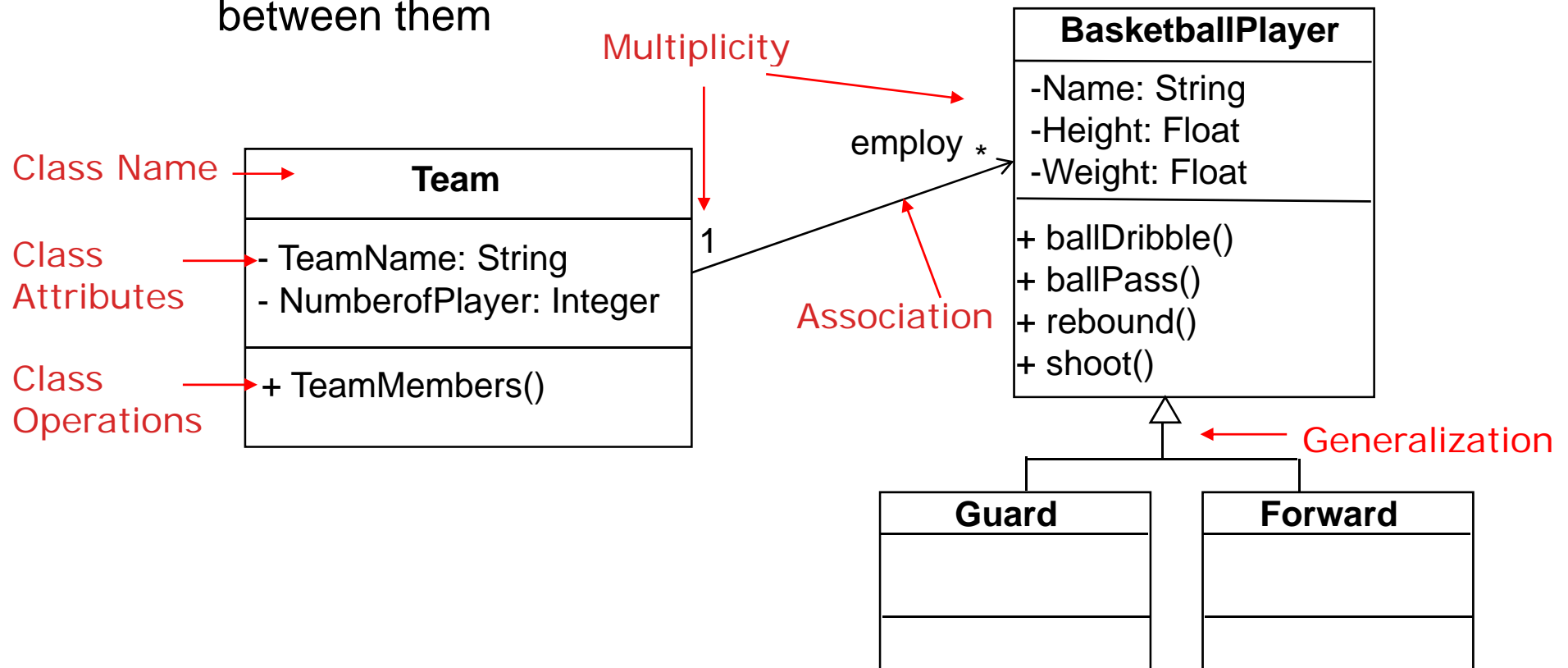

Classes

- Most important building block of any object-oriented system
- Description of a set of objects
- Abstraction of the entities
 - Existing in the problem/solution domain

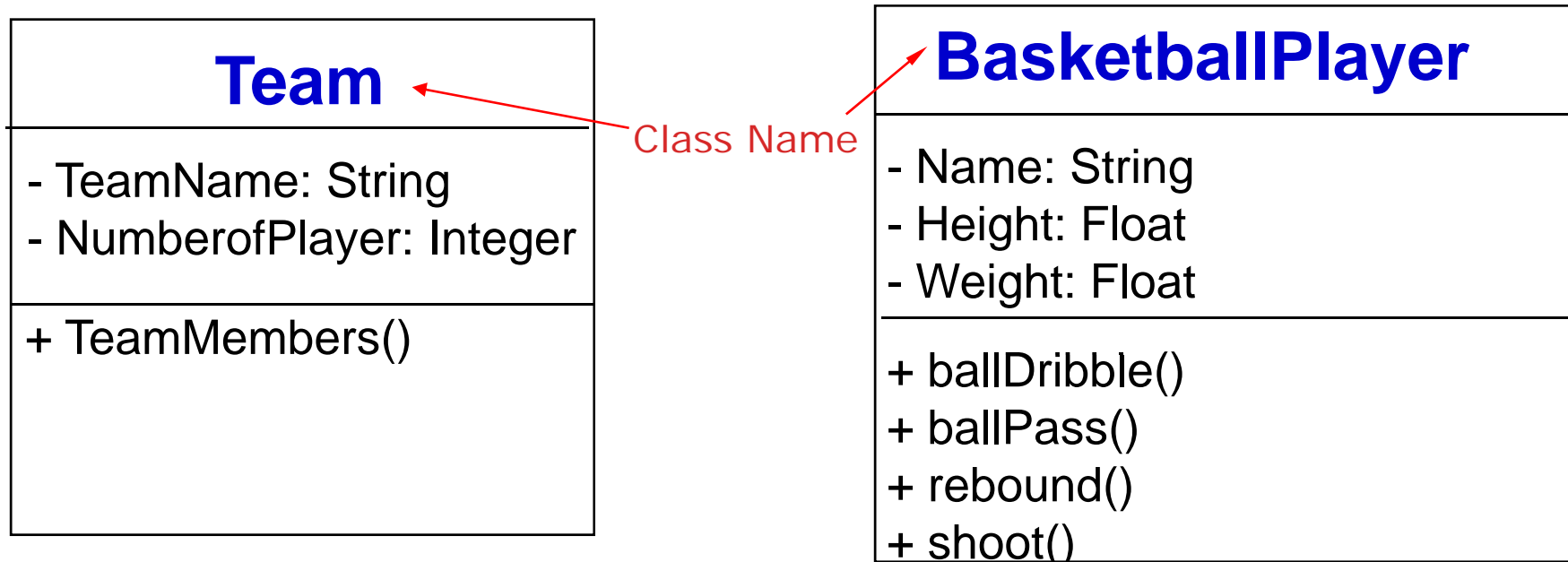

Attributes and Operations

- Attributes
 - Represent some property of the thing being modeled
 - Syntax: attributeName : Type
- Operations
 - Implement of a service requested from any object of the class
 - Syntax: operationName(param1:type, param2:type, ...) : Result

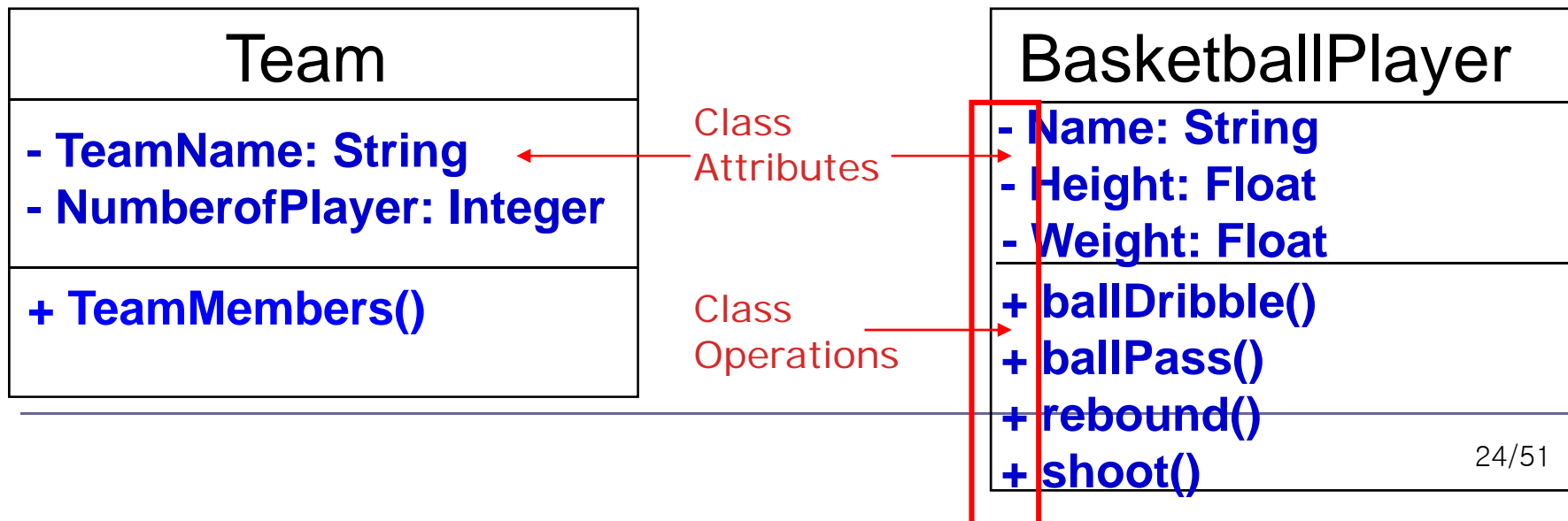

Association and Multiplicity

- Association
 - Relationship between classes that specifies connections among their instances
- Multiplicity
 - Number of instances of one class related to ONE instance of the other class

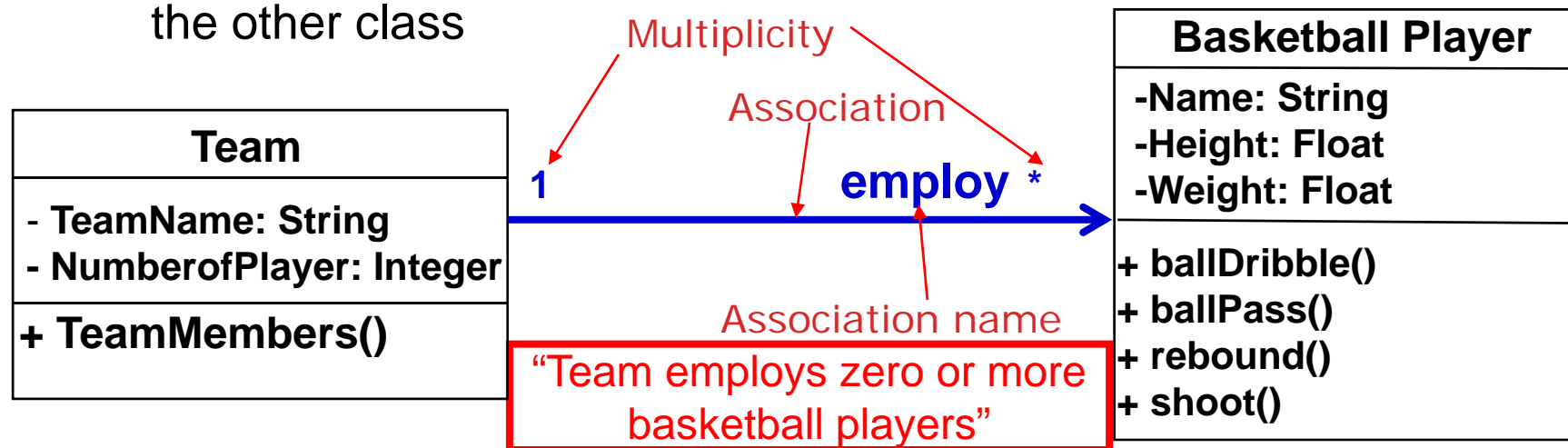

Aggregations and Compositions

- Aggregation
 - **Weak** “whole-part” relationship between elements
 - An airport has many airplanes in it.
- Composition
 - **Strong** “whole-part” relationship between elements
 - Window ‘contains a’ scrollbar

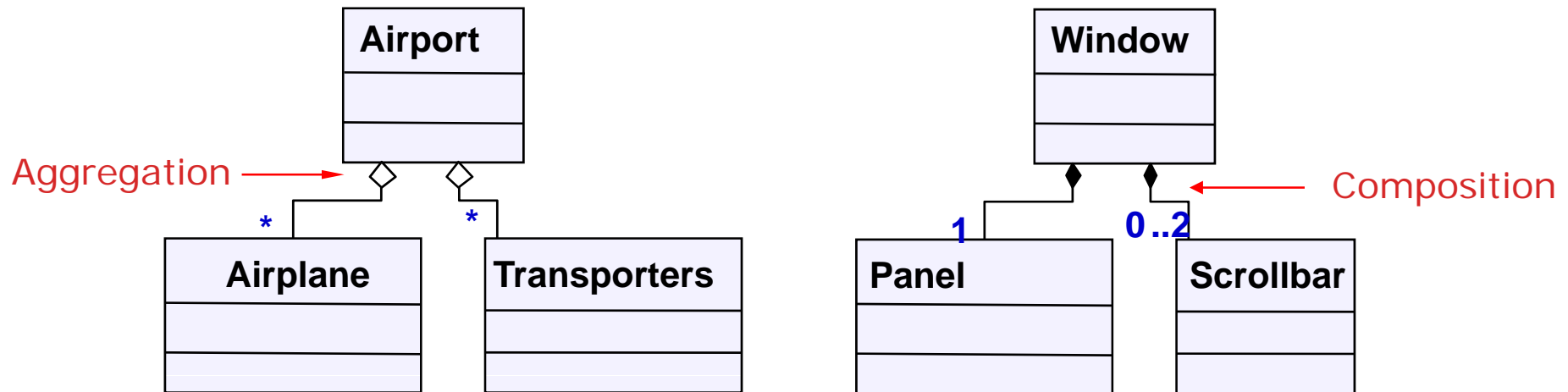

Inheritance

- Relationship between superclass and subclasses
 - All attributes and operations of the superclass are part of the subclasses

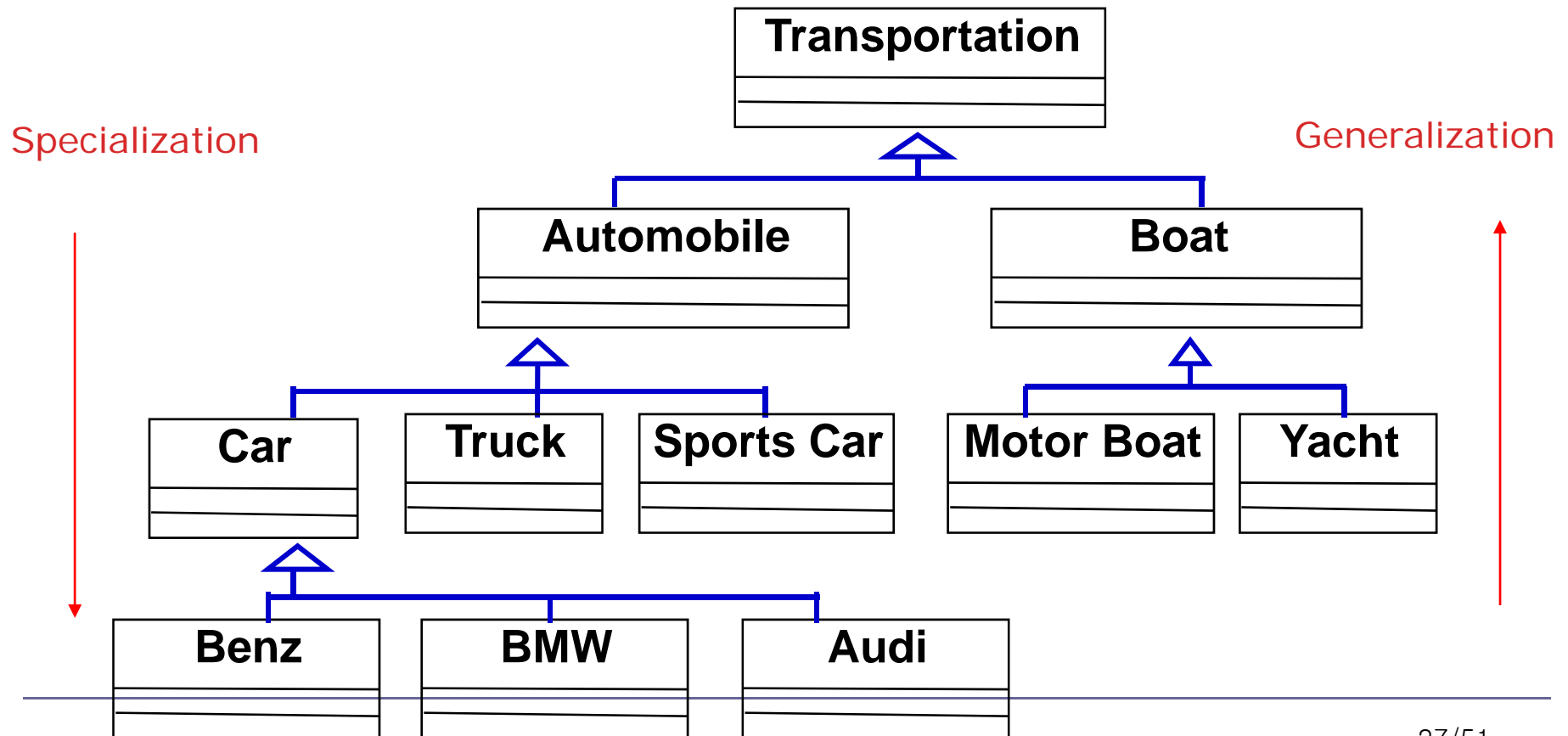

Active vs. Passive Class

- Active class
 - Own a **thread control** and can initiate control activity
 - Used when asynchronous communication is necessary
 - Typically modeled with a state machine of its behavior
 - Encapsulated with **ports** and **interfaces**
- Passive class
 - Own address space, but not thread of control
 - Executed under a control thread anchored in an active object

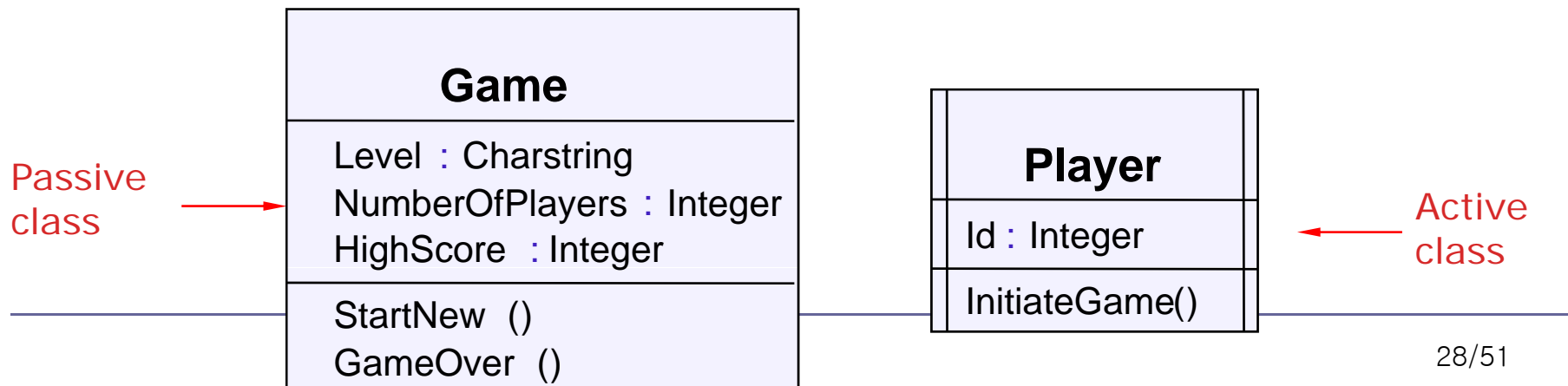

Ports and Interfaces

- Ports
 - Define an interaction point on a classifier with external environment
- Interfaces
 - Describe behavior of objects without giving their implementations
 - Each class implements the operations found in the interface

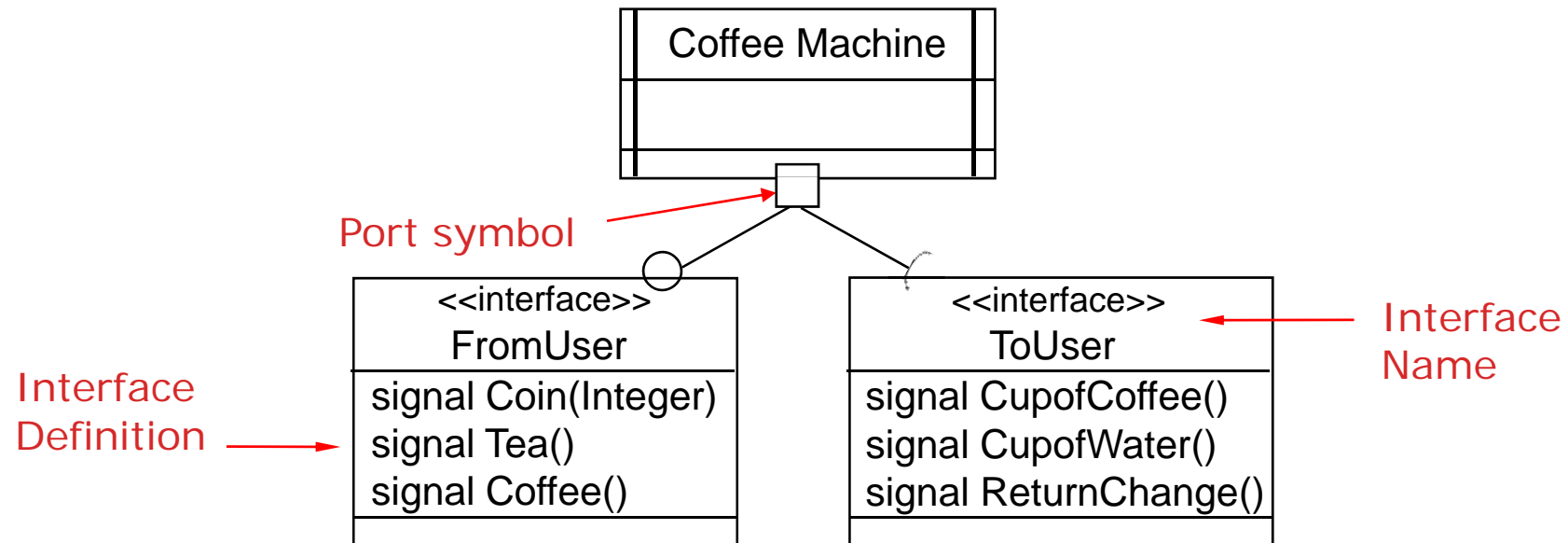

Provided/ Required Interface

- Provided interface
 - Class provides the services of the interface to outside callers
 - What the **object can do**
 - Services that a message **to** the port may request (incoming)
- Required interface
 - Class uses to implement its internal behavior
 - What the object **needs to do**
 - Services that a message **from** the port may require from external environment (outgoing)

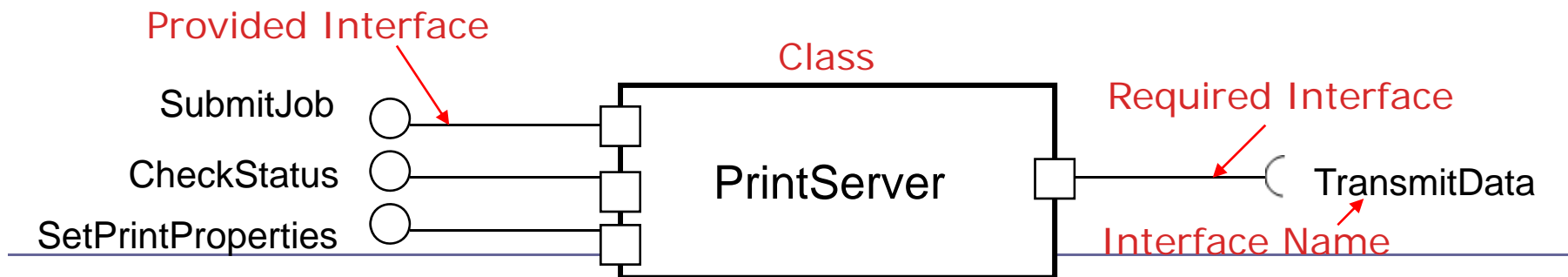

Computer Device Example

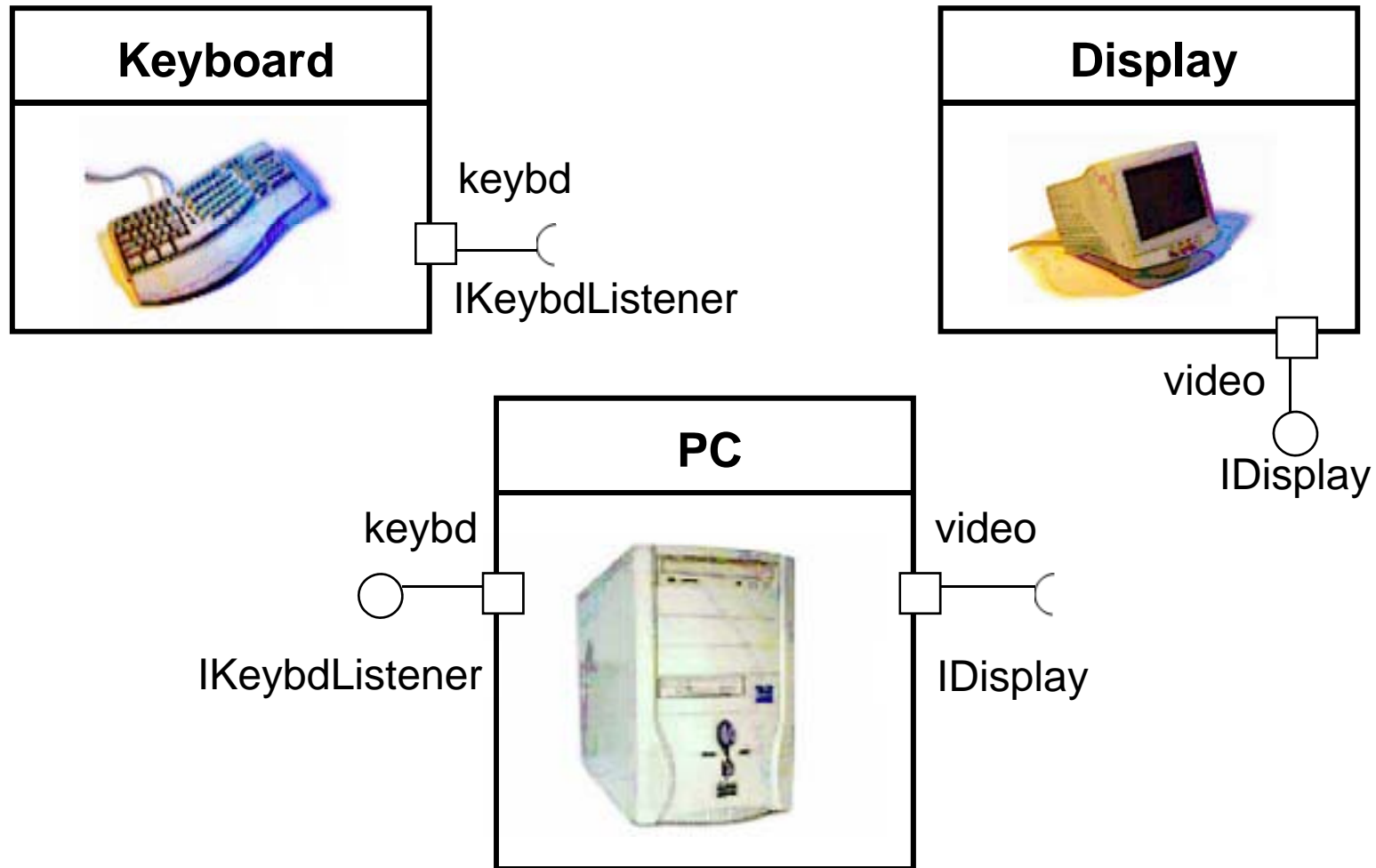

Tips for Class Modeling

- Finding Classes
 - Do we have that should be stored or analyzed ?
 - Do we have external system ?
 - **External system is modeled as class**
 - Do we have any patterns, class libraries, components, and so on ?
 - Are there devices that the system must handle ?
- Make explicit **traceability** whenever possible
 - Try to capture classes/attributes from nouns of use-cases and operations from verbs of use-cases
 - Always draw class diagram in conjunction with some form of behavioral diagrams

(From :oopsia.snu.ac.kr/research/UML/)



Sequence Diagrams

Sequence Diagrams

- Show sequences of messages (“interactions”) between instances in the system
- Emphasize time ordering

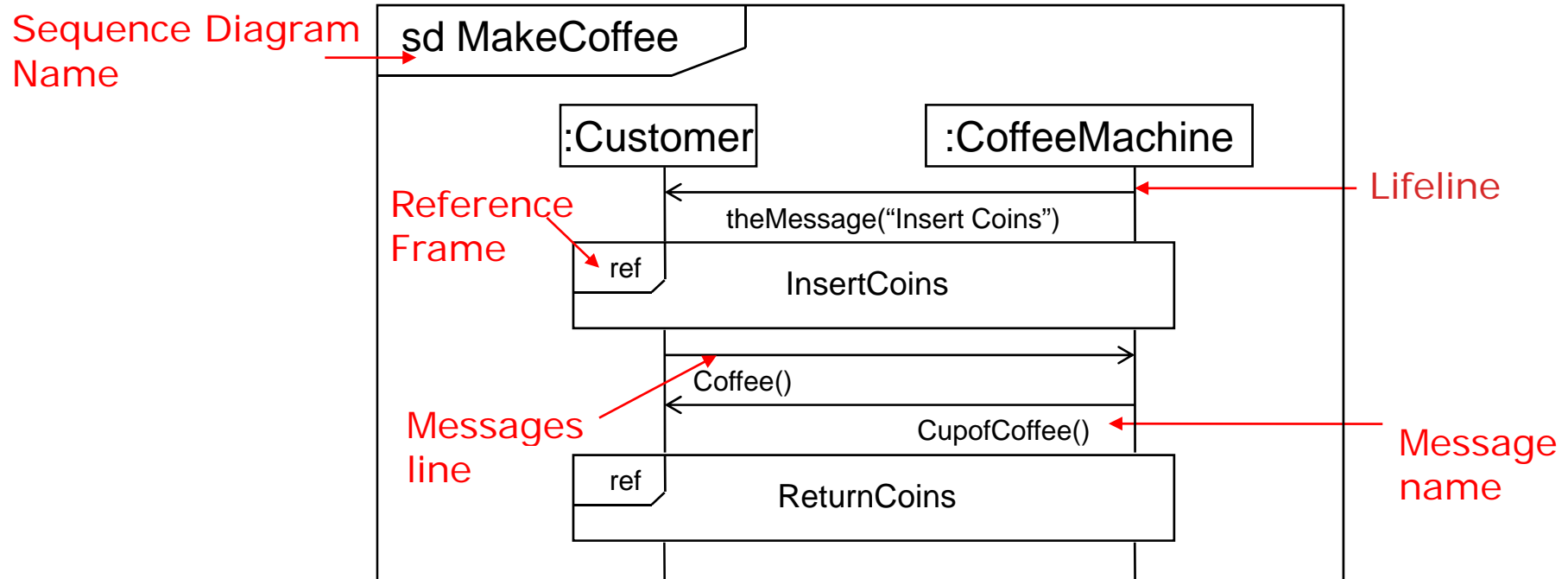

Lifelines

- Individual participant in the interaction over period time
 - Subsystem/ object/ class
 - Actor

Instance name (object) :
Type name (class)

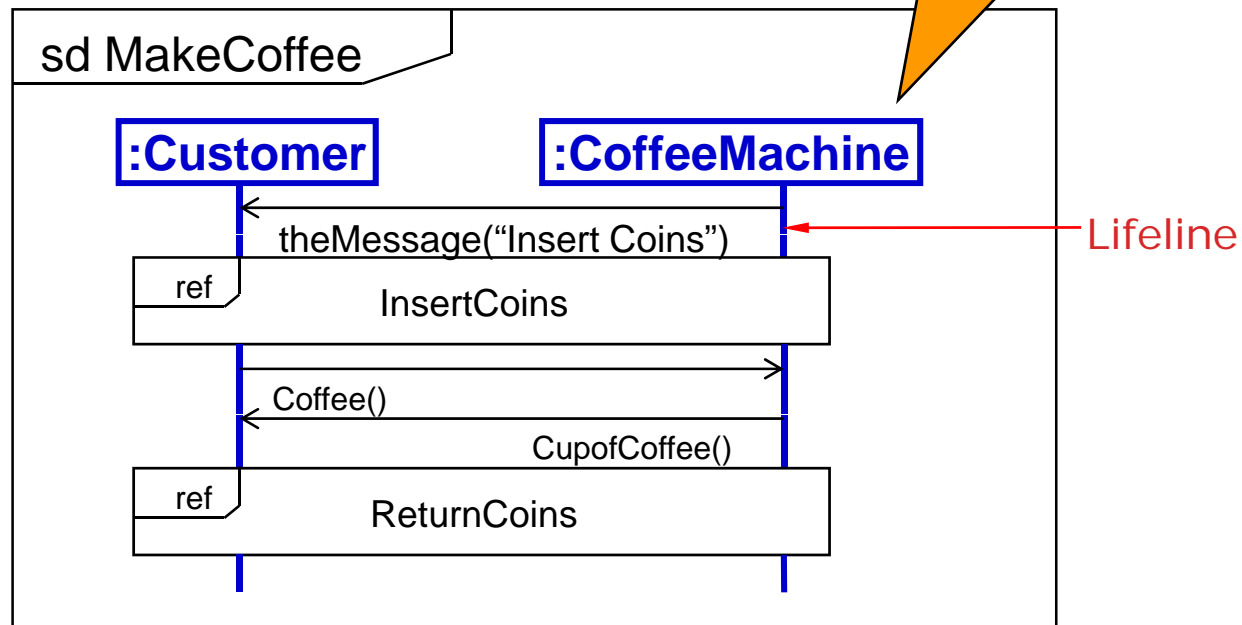

Messages

- One-way communication between two objects
- May have parameters that convey values

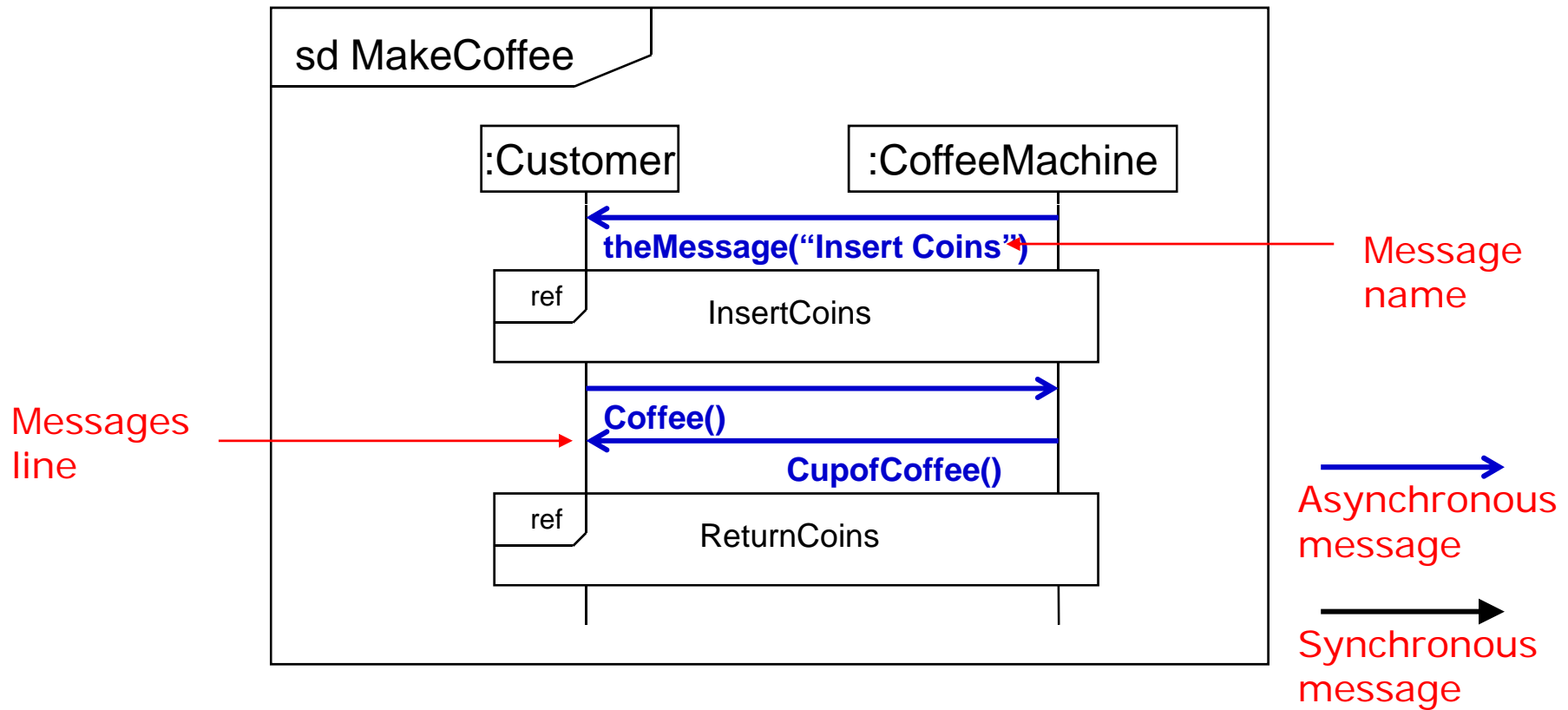

Combined Fragment Frame

- Defines an expression of interaction fragments
- Interaction operators define how the contents describe behavior
 - Alt: each section is one alternative
 - E.g. **alt [a>0]**
 - Ref: reference to another Use Case
 - Loop: specifies a repeated sequence of behavior
 - E.g. **'loop [1,5]'**, **'loop [6]'**

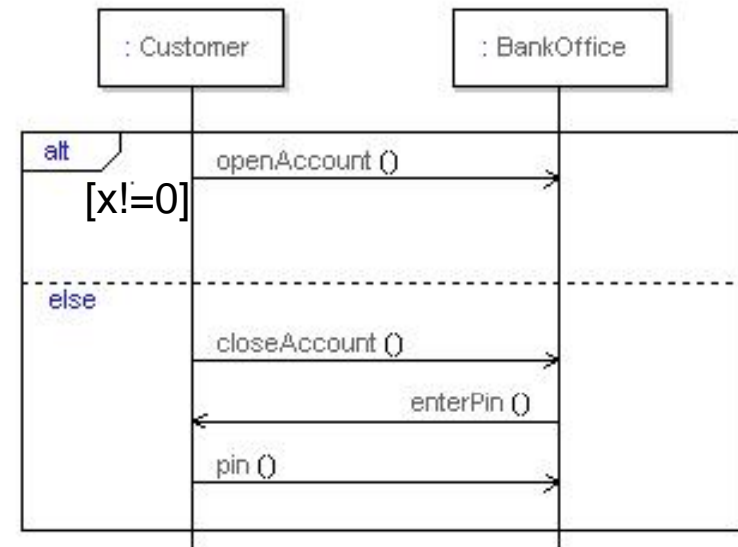

Referencing

- Reuse already existing sequence diagrams
 - Avoid unnecessary duplication

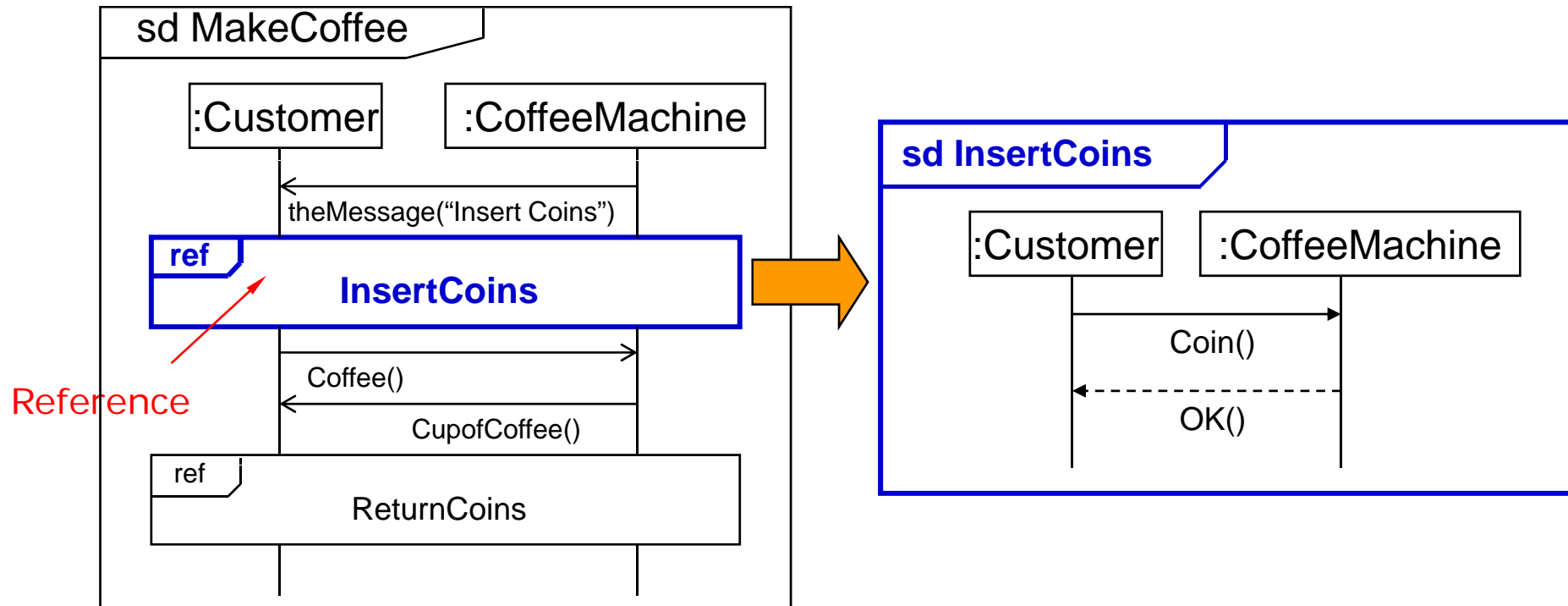

Tips for Sequence Diagram

- Set the **context** for the interaction.
 - E.g. one use case
- Express the flow from left to right and from top to bottom.
- Put active instances to the left/top and passive ones to the right/bottom.
- Draw sequence diagrams for each use-case if you want to look at the behavior of several objects

(From [:oopsia.snu.ac.kr/research/UML/](http://oopsia.snu.ac.kr/research/UML/))



State Machine Diagrams



State Machine Diagrams

- Describe the dynamic behavior of **objects** over time by modeling the lifecycles of **objects of each class**
- Show
 - The **event** that cause a transition from one state to another
 - The **actions** that result from a state change

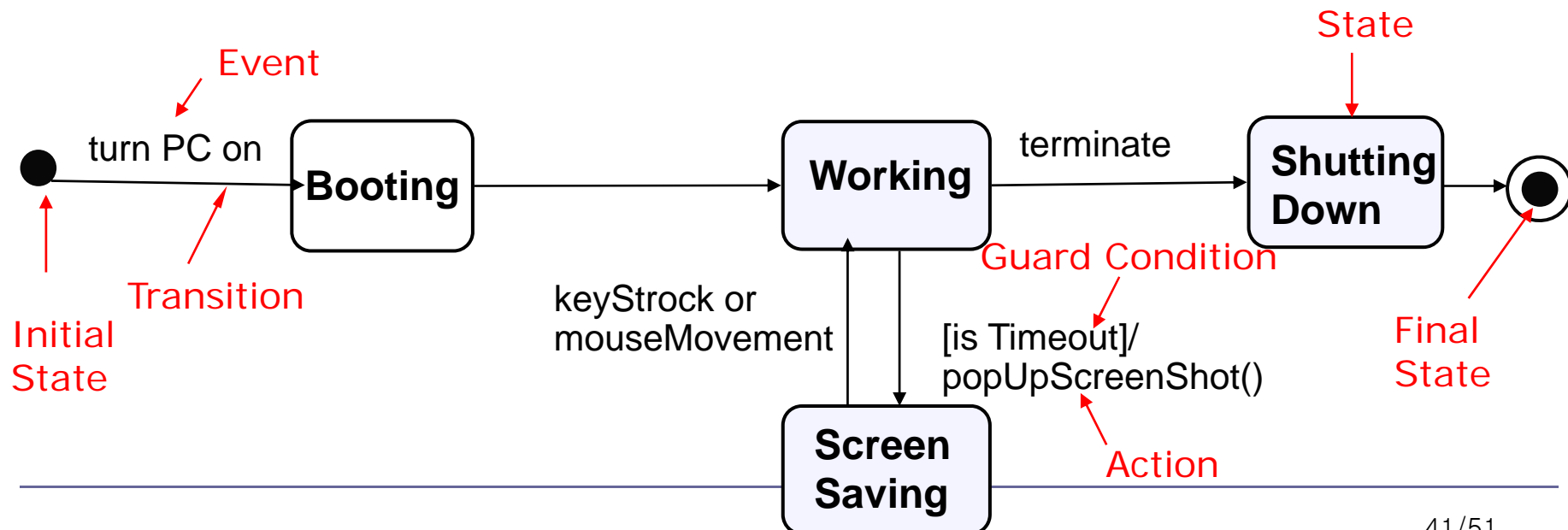

States

- State

- Condition or situation during the life of an object

- Satisfies some condition, performs some activity or waits for some event

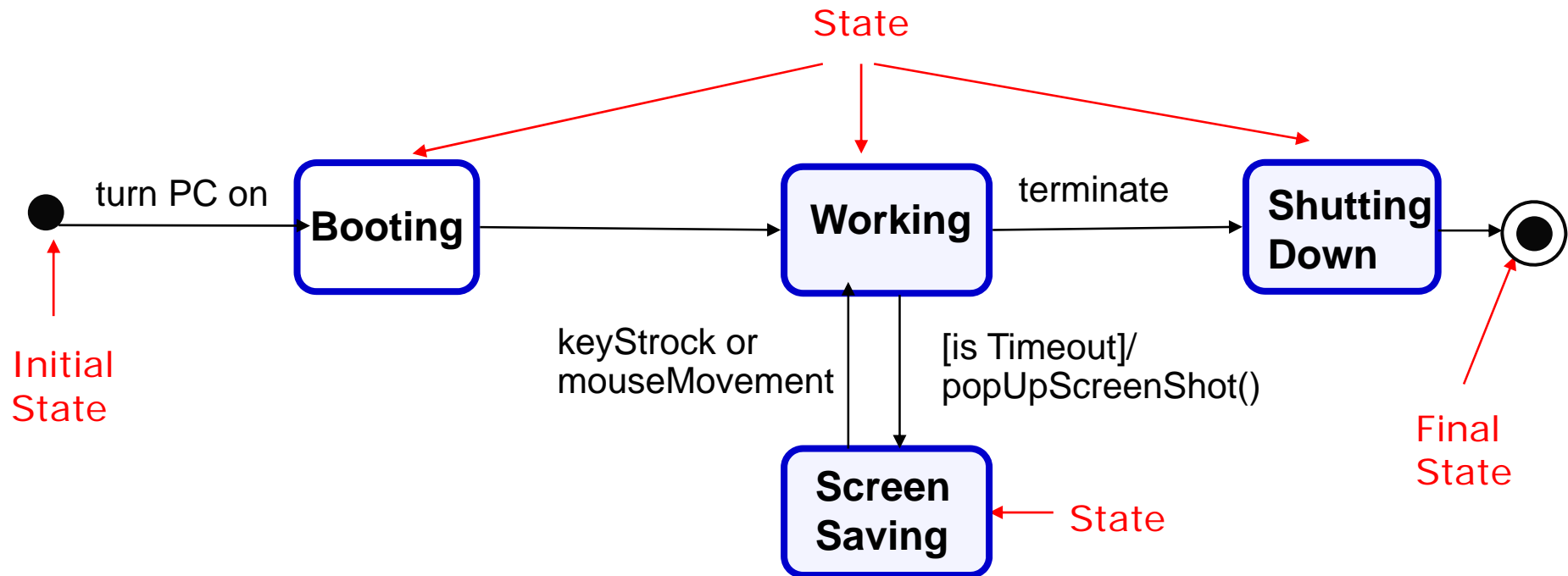

Event and Action

- Event
 - Stimulus which causes the object to change state
- Action
 - Output of a signal or an operation call

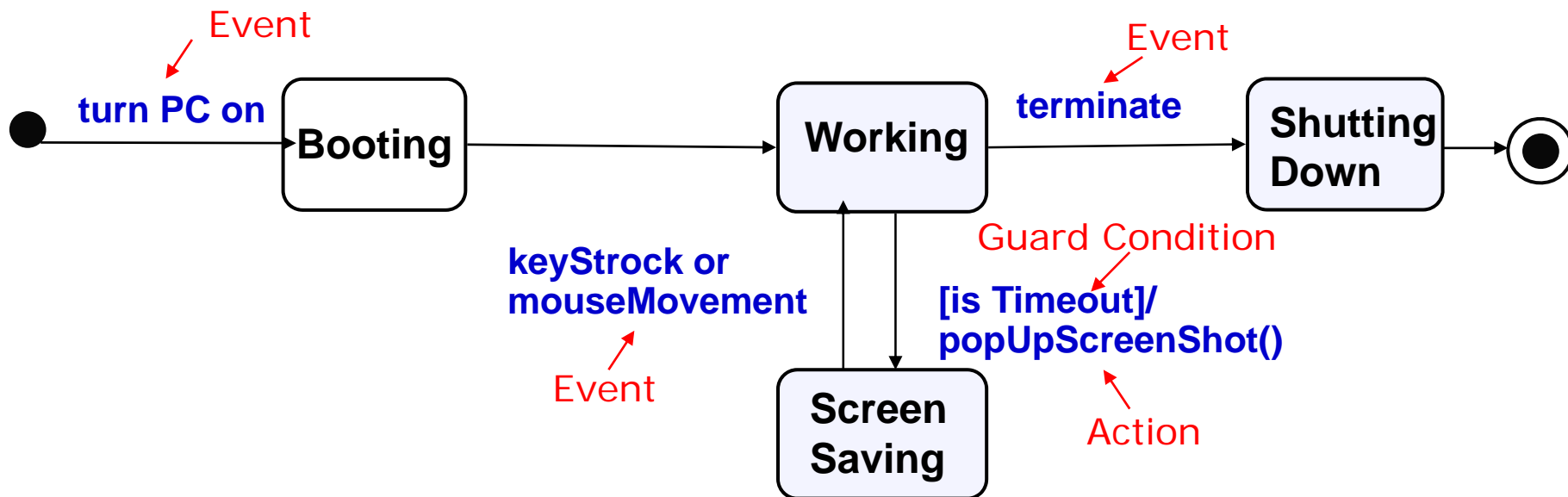

Transition

- Change state from one to another triggered by an event
- Occur only when guard condition is true
- Syntax: event(arguments)[condition]/action

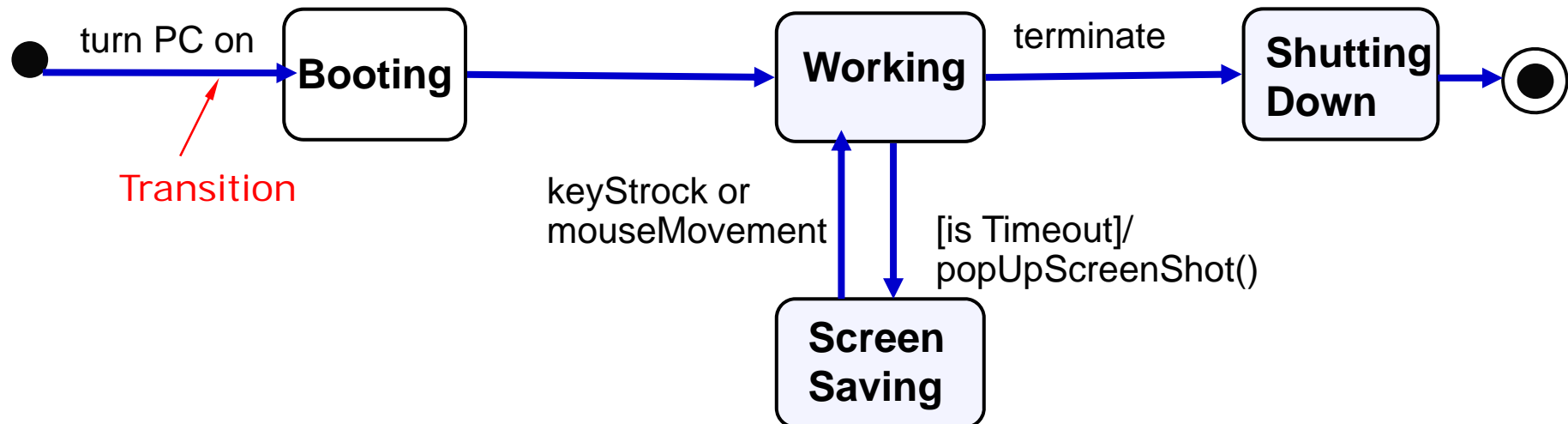

Internal Activities

- States can react to events without transition
 - Putting the event, guard, and activity inside the state box
 - Two special activities
 - **The entry and exit activities**
- Internal activity is similar to self-transition
 - However, internal activities do not trigger the entry and exit activities

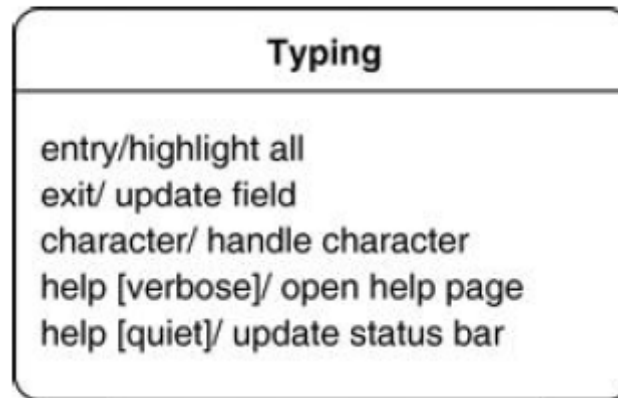

Activity States

- Regular activities
 - Instantaneous behavior
 - Cannot be interrupted
- A normal state is quiet and waiting for the next event before it does something
- Do-activities
 - Takes finite time
 - Can be interrupted
- Activity state is doing some on-going work

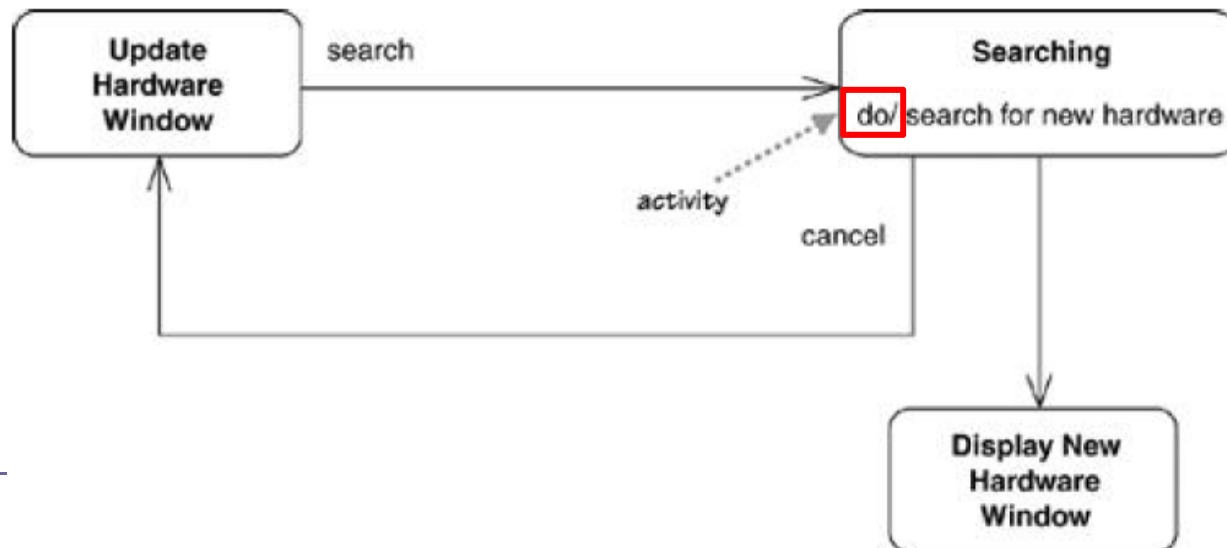

Superstates

- Several states share common transitions and internal activities
 - Move the shared behavior into a superstate
 - A behavior can be expressed in a modular/hierarchical way

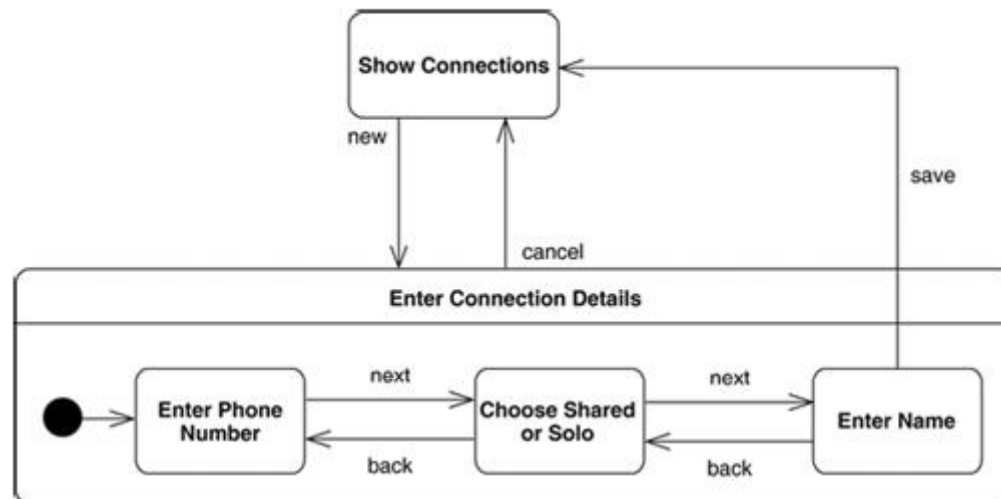



Deployment Diagrams



Deployment Diagrams

- Show runtime architecture of devices, execution environments, and artifacts in architecture
 - Physical description of system topology

- Describe structure of hardware units and software executing on each unit

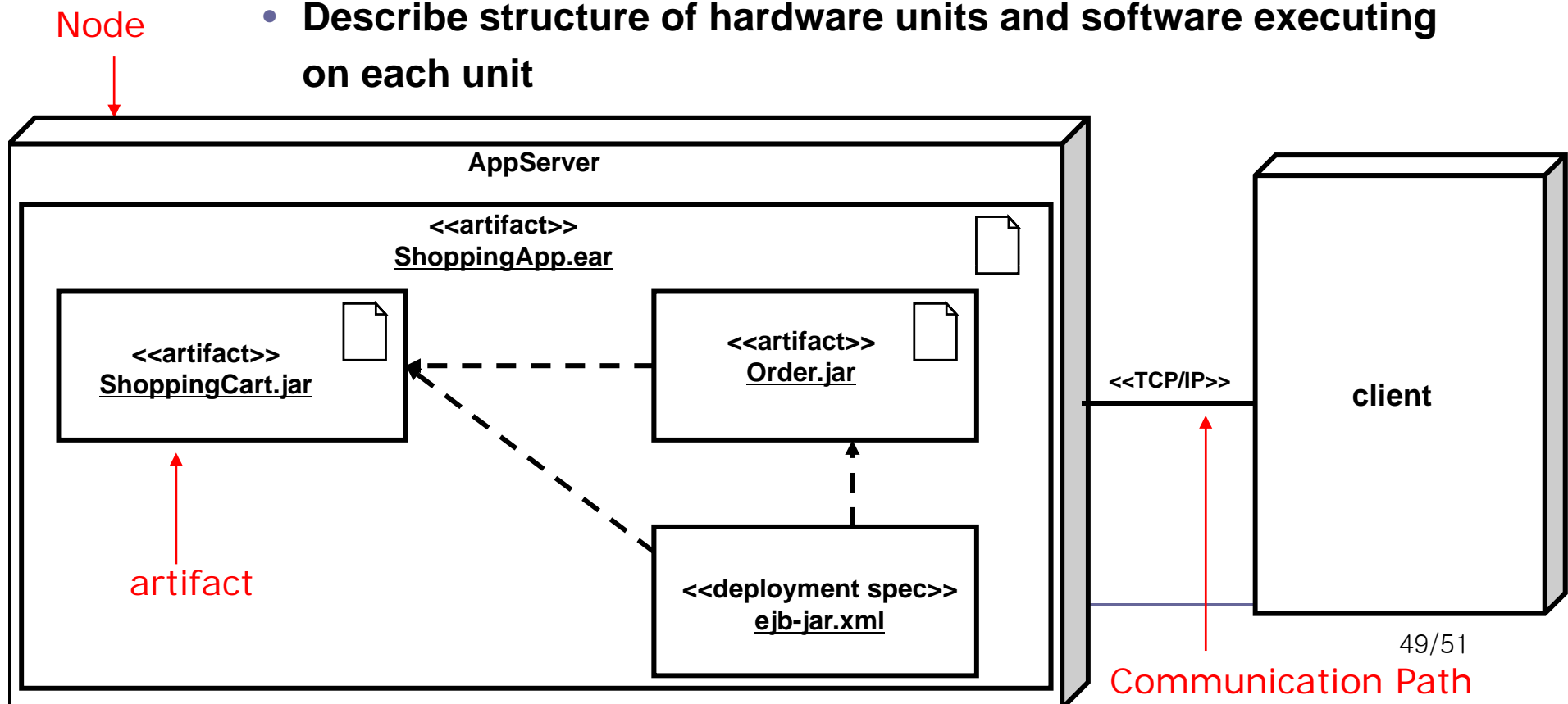

Deployment Diagrams

- Node
 - Computational resource upon which artifacts may be deployed for execution
- Communication path
 - Show connection between nodes
 - **Stereotype can be used for communication protocol or network used**
- Artifact
 - Specification of a physical piece of information that is used or produced by a software development process, or by deployment and operation of a system.
 - **Examples of artifacts include model files, source files, scripts, and binary executable files, a table in a database system, a development deliverable, or a word-processing document, a mail message.**

Summary

- UML can be used as
 - Sketch level
 - Blue print level
 - Programming language level
- Use appropriate UML diagrams for different goals
 - If you just starts your SE projects, **start** with
 - **Use-case diagrams with use-case texts**
 - If you want to look at behavior across **many use cases** or many threads,
 - **Activity diagram**
 - If you want to look at the behavior of **several objects** within a single use case,
 - **Sequence diagrams**
 - If you want to look at the behavior of a **single object** across many use cases,
 - **State diagrams**

